

**DESCRIPTION**

The UCAN Tie Wire Wedge Anchor is a steel fastener, designed primarily for suspended ceiling installation. The anchor consists of a steel body with 9/32" diameter wire hole and a one piece wrap around expansion clip.

**FEATURES**

- Wrap around expansion clip provides true 360° expansion
- Non-bottom bearing type
- Fast, simple installation by hammer
- Anchor has follow-up expansion feature
- Rigid, one piece fastening
- Zinc Plated

**LIMITATIONS**

Not recommended for uncured concrete (less than 7 days of curing).

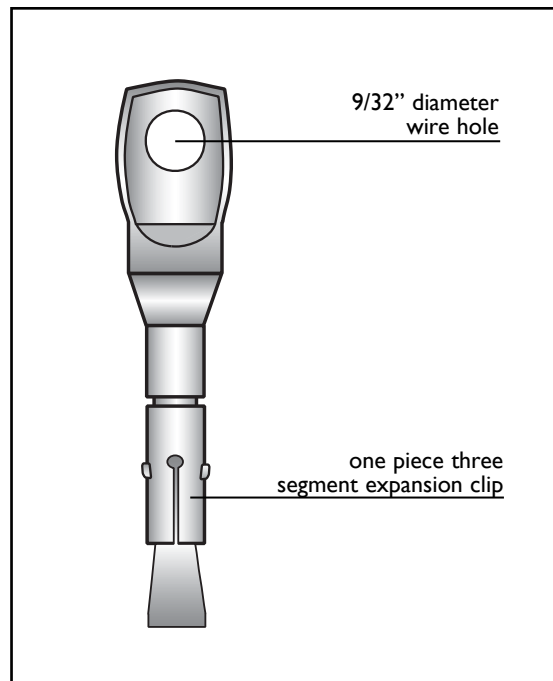

**MATERIAL SPECIFICATIONS**

**Anchor body**

- Grade AISI C1022
- Minimum tensile strength - 75,000 psi
- Average yield strength - 60,000 ps

**Sleeve**

- Cold rolled steel, AISI C1050

**Corrosion protection**

- The anchor body and expansion clip are zinc plated.

**TECHNICAL DATA**

Drilled Hole Diameter	1/4"
Embedment	1-1/8"
Ultimate Tension Load In 2,500 psi Concrete	1,800 lbs
	8.00 kN
Ultimate Tension Load In 4,000 psi Concrete	2,200 lbs
	9.79 kN

Note: Load data is provided as a guide only.

**INSTALLATION**

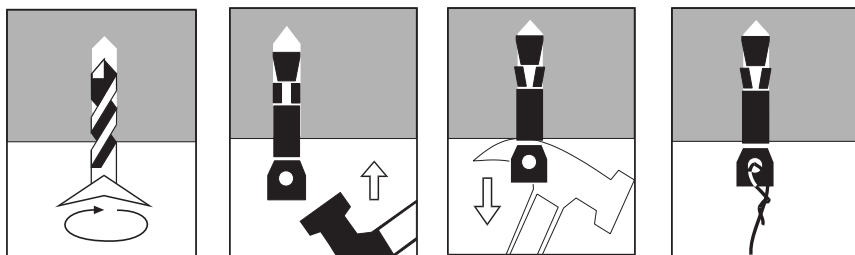

**NOTE:**  
 Apply Safety Factor to ensure the working load per anchor does not exceed 1/4 of the tabulated ultimate load, under static loading conditions.