

DESCRIPTION

Rust proof zamac alloy machine type expansion anchor ideally suited for base materials of questionable strength. The single and double expansion anchor consists of pre-assembled sets of shields and an internally threaded expander cone.

TYPICAL APPLICATIONS

- Timber frames to concrete
- Steel or wood fastening in corrosive environment
- Fastening to brick and block walls

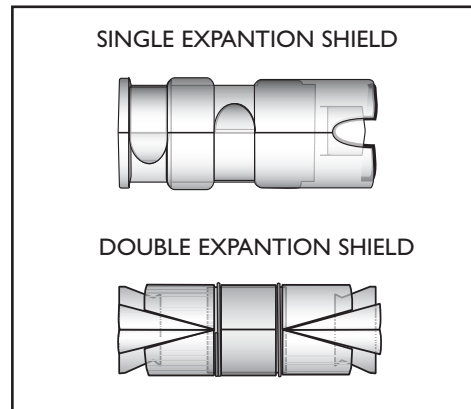

**SINGLE EXPANSION SHIELD PERFORMANCE DATA
 IN 3000psi CONCRETE**

Part Number	SIZE	ULTIMATE TENSION LOAD	ULTIMATE SHEAR LOAD
USA 14	1/4	1,800	2,150
USA 516	5/16	2,000	3,300
USA 38	3/8	2,260	3,950
USA 12	1/2	3,500	8,000
USA 58	5/8	5,800	13,500
USA 34	3/4	8,500	15,000

**DOUBLE EXPANSION SHIELD PERFORMANCE DATA
 IN 3000psi CONCRETE**

Part Number	SIZE	ULTIMATE TENSION LOAD	ULTIMATE SHEAR LOAD
UDA 14	1/4	1,900	2,800
UDA 516	5/16	2,150	3,750
UDA 38	3/8	4,000	4,500
UDA 12	1/2	4,500	9,000
UDA 58	5/8	5,600	13,000
UDA 34	3/4	9,000	15,900